

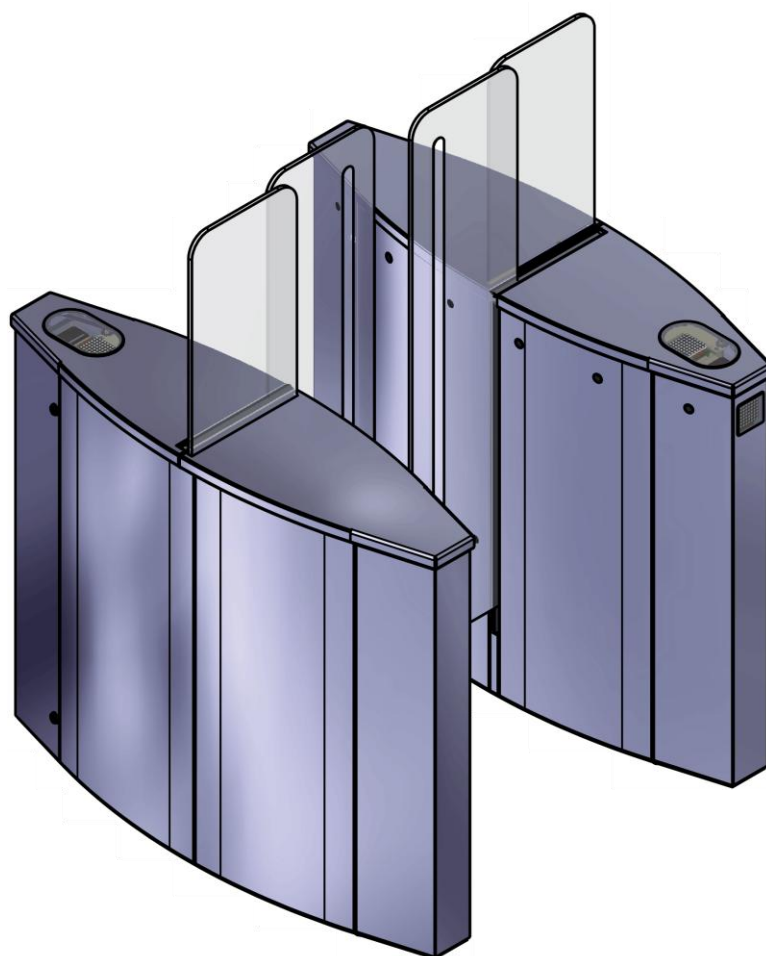

«TiSO-PRODUCTION» Company

**WAIST-HIGH TURNSTILE
T3.KCD.XK.X**



JETPAN

**OPERATION MANUAL
AUIA.165 OM**

2013

CONTENTS

	Page
INTRODUCTION.....	3
1 DESCRIPTION AND OPERATION.....	5
1.1 General Information and Designation.....	5
1.2 Specifications.....	6
1.3 Configuration and Completeness of Delivery.....	6
1.4 Design and Operation.....	9
1.5 Instrumentation, tools and accessories.....	11
1.6 Marking.....	11
1.7 Packing.....	12
1.8 Description and operation of controller as component of the turnstile.....	12
2 INTENDED USE.....	15
2.1 Operating limitations.....	15
2.2 Layout and installation.....	16
2.3 Preparation for use.....	16
2.4 Contingency actions.....	17
3 MAINTENANCE.....	17
3.1 General instructions.....	17
3.2 Safety measures.....	18
3.3 Maintenance procedure.....	18
4 ROUTINE MAINTENANCE.....	18
4.1 General instructions.....	18
4.2 Fault Directory.....	18
4.3 Post repair checkout.....	19
5 TRANSPORTATION AND STORAGE	19
6 UTILIZATION.....	19
7 MANUFACTURER’S WARRANTY AND CONDITIONS OF INTERMEDIATE MAINTENANCE.....	20
Appendix A Design and overall dimensions of the rotor turnstile T3.KCD.XK.X of «JETPAN» type.....	21
Appendix B Control panel and connection diagram.....	23
Appendix C Wiring diagram of the turnstile T3.KCD.XK.X of «JETPAN» type.....	25

INTRODUCTION

This Operation Manual (hereinafter referred to as the OM), combined with certificate, covers the waist-high turnstile of «JETPAN» type with servomotor (hereinafter referred to as the turnstile).

The Operation Manual contains information about design, specifications, installation, proper operation and maintenance of the turnstile.

This Operation Manual is prepared in compliance with the specification requirements TU
U 31.6-32421280-004:2010.

The turnstile should be serviced only by the qualified staff having the relevant class of permit to work with electrical facilities with voltage up to 1000V, who carefully studied this Operation Manual, obtained safety instructions and trained for operation and maintenance of the turnstile.

Reliability and durability of the turnstile operation is provided with observation of modes and conditions of transportation, storage, installation and operation. So, fulfillment of all requirements specified in this document is mandatory.

The turnstile «JETPAN» can be installed both singly and in line. One turnstile includes two pedestrian gates (left-hand and right-hand), each of which is equipped with one glass leaf.

Line of turnstiles is implemented by installation of one more or several extra pedestrian gates, which are equipped with glass leaves from both sides providing cost effectiveness and space saving.

Reference designation of the turnstile:

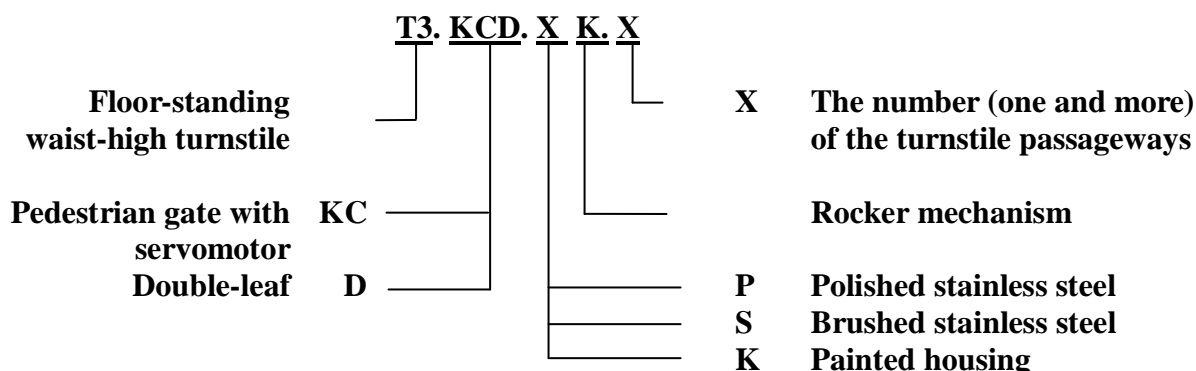

Example of reference designation of the single «JETPAN» type turnstile of consisting of left-hand and right-hand pedestrian gates made from brushed stainless steel when the turnstile

T3.KCD.SK.1 TU U 31.6-32421280-004:2010 is ordered.

Example of reference designation of the double turnstile consisting of left-hand, right-hand and an extra pedestrian gates with servomotor made from polished stainless steel when the turnstile

T3.KCD.PK.2 TU U 31.6-32421280-004:2010 is ordered.

Due to regular upgrading of the turnstile its design can be modified without degradation of its features and quality.

WARNINGS TO THE CUSTOMER ON SAFE OPERATION OF THE TURNSTILE

These warnings are designed for ensuring of safety during operation of the turnstile to prevent violation of safety characteristics by improper installation or operation. These warnings are aimed at drawing attention of the customer to safety problems.

GENERAL WARNINGS

Safety measures and requirements specified in this in this OM must be observed:

- the turnstile must be connected to ground loop prior to operation;
- the turnstile should be connected to AC network with parameters specified in the paragraph 1.2 «Specifications»;
- inspection, adjustment and repair should be performed only after the turnstile is deenergized.

After purchasing of the turnstile it should be unpacked and its integrity should be checked. In case of doubt in integrity of the turnstile it should not be used and the customer should refer to the supplier or to the manufacturer.

Packing accessories (wooden pallet, nails, clips, polyethylene bags, cardboard etc.) as potential sources of hazard must be removed to unacceptable place prior to proper use of the turnstile.

As electric shock protection device the turnstile is related to 01 protection class according to the GOST (State Standard) 12.2.007.0-75 and is not intended for operation in explosive and fire-hazardous areas by the «Rules for design of electrical installations».

Using of the turnstile for unintended purpose, improper installation, nonobservance of conditions of transportation, storage, installation and operation specified by this OM, may result in damage to people, animals or property for which the manufacturer is not responsible.

1 DESCRIPTION AND OPERATION

1.1 General Information and Designation

1.1.1 Name of product: Turnstile of «JETPAN» type

Climatic version: NF4

1.1.2 The motorized turnstile is designed for pedestrian movement control at access points of industrial enterprises, banks, stadiums, administrative facilities etc. by access control system (from magnetic card readers, keypad etc.) or manually (from manual control panel).

Traffic flow capacity of the single turnstile with personal identification is at least 30 persons per minute in one direction.

1.1.3 Dimensions of the turnstile correspond to the values specified in the Table 1.

Table 1

Designation of modification		Dimensions, mm			Maximum weight, kg
		H	L	B	
Single turnstile	Double turnstile	1540	1184	1214	288
T3.KCD.PK.1	–				
T3.KCD.SK.1					
T3.KCD.KK.1					
–	T3.KCD.PK.2	2034	469		
	T3.KCD.SK.2				
	T3.KCD.KK.2				

* When the turnstile with more than two passageways is ordered:
 $L = 516 \cdot X + 334 \cdot Y$,
 where X – number of passageways;
 516 – passageway width, mm;
 334 – pedestrian gate width, mm;
 Y – total number of pedestrian gates in the turnstile, pcs.
 Example of calculation of size L for T3.KCD.PV.4 (quadruple turnstile): $L = 516 \cdot 4 + 334 \cdot 5 = 3734$ mm

1.1.4 Code of the turnstile component is specified in the Table 2.

Table 2

Name of turnstile component	Code	Dimensions, mm			Maximum weight, kg
		H	L	B	
Extra pedestrian gate	T3.KCD.PK	1540	334	1214	181
	T3.KCD.SK				
	T3.KCD.KK				
Left-hand/right-hand pedestrian gate	–				144

1.1.5 The parameters defining operation conditions according to GOST 15150-69 and GOST 12997-84 are specified in the Table 3.

Table 3

Operation conditions	For climatic version	Parameter value
Ambient temperature	NF4	+1 to + 40°C
Relative humidity		80% at + 20°C
Ambient temperature allowable pressure		84 to 106,7kPa
Transportation temperature range		- 40°C to + 50°C

Storage temperature range	+ 5 to + 40°C
Group of mechanical application	L3
Altitude above sea level	up to 2000m
Environment	Explosion-proof, does not contain current-conducting dust, aggressive gases and vapours in concentration destroying isolation and metals, disturbing normal operation of the equipment installed in turnstiles
Installation site	In enclosed spaces in the absence of direct impact of precipitations and solar radiation
Running position	Vertical, deviation from vertical position no more than 1° to any side is tolerated

1.1.6 Reliability indices:

- mean time to repair (without delivery time of spare parts, tools and accessories) – at most 6 hours;
- mean time to failure – at least 1 500 000 accesses;
- mean service life between overhauls – at least 10 years.

1.2 Specifications

Principal parameters of the single turnstile are specified in the Table 4.

Table 4

Parameter description	Unit measure	Parameter value
Traffic flow capacity in single access mode is at least	man/min.	30*
Opening/closing time	sec.	0,8
Max. passage width	mm	516
Supply voltage:		
– AC power supply (primary)	V Hz	100÷240 ~ 50/60
– DC power supply (secondary)	V	12
Max. power consumption	V·A	200*
Index of protection according to GOST 14254-96	–	IP41
* Parameter is multiplied by number of accesses for the turnstiles with number of accesses more than one		

1.3 Configuration and Completeness of Delivery

1.3.1 The turnstile modification depends on the number of arranged accesses:

- 1) for arrangement of single access the turnstile is a set of left-hand and right-hand pedestrian gates, each of which is equipped with one glass leaf (reference designation T3.KCD.XK.1);
- 2) for arrangement of two or more accesses the turnstile is a set of two pedestrian gates and one or more extra pedestrian gates with two leaves (reference designation T3.KCD.XK.X).

Arrangement of accesses for the one turnstile T3.KCD.XK.1 is shown in the Figure 1.

1.3.1.1 Design of the single «JETPAN» type turnstile

The base model is a single turnstile consisting of two one-leaf pedestrian gates (left-hand and right-hand).

Housing of each pedestrian gate consists of:

- frame;
- base;
- set of side panels;
- top cover;

- extension device with glass leaf;
- crossbar with glass;
- two LED displays.

There are installed inside pedestrian gate:

- terminal block;
- controllers;
- seven access sensors;
- proximity card reader (to be equipped by the Customer, if required);
- power supply unit.

Optionally the turnstile can be completed with battery. For a single turnstile control desk with power supply unit, circuit breaker and battery mounted on it to be installed only in the right-hand pedestrian gate from the protected area side.

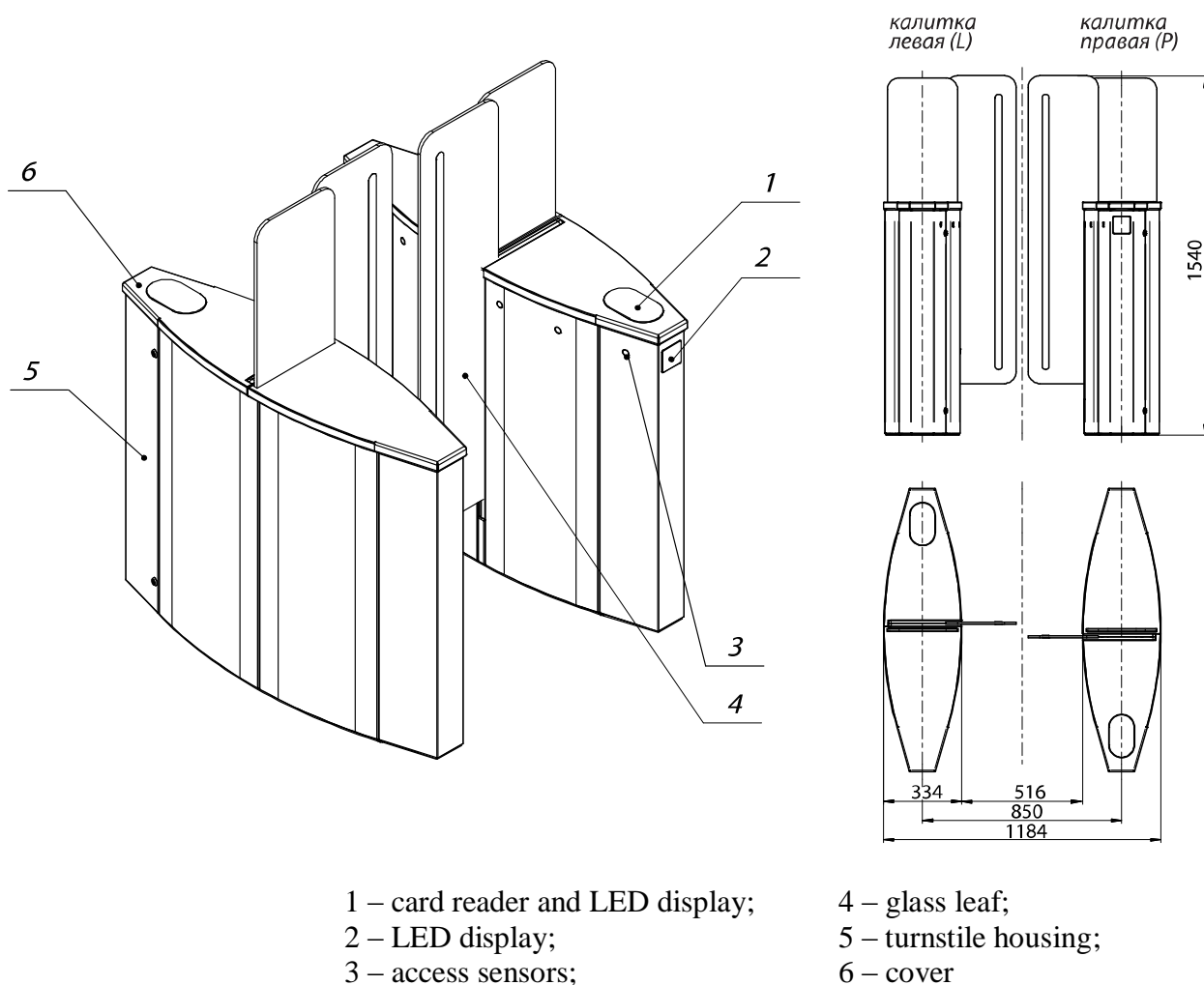

Figure 1 – Single «JETPAN» type turnstile

Arrangement of accesses for the double turnstile T3.KCD.XK.2 is shown in the Figure 2.

1.3.1.2 Design of the double «JETPAN» type turnstile

The double turnstile is a set of two one-leaf pedestrian gates (left-hand and right-hand) and an extra pedestrian gate with two extensible glass leaves.

Housing of each pedestrian gate consists of:

- base;
- set of side panels;
- top covers;

- extension devices with extensible glass leaves;
- crossbar with glass;

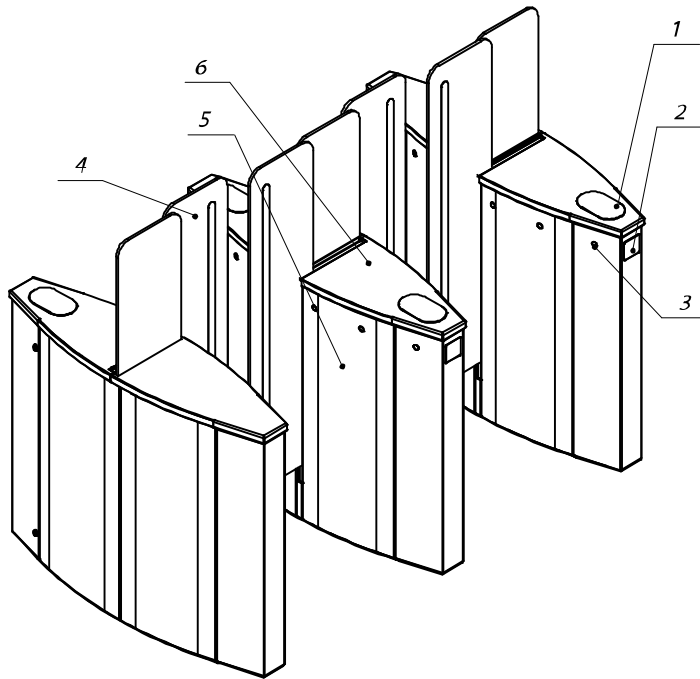

- 1 – card reader and LED display;
- 2 – LED display;
- 3 – access sensors;
- 4 – glass leaf;
- 5 – turnstile housing;
- 6 – cover

Figure 2 – Double «JETPAN» type turnstile

left-hand pedestrian gate extra pedestrian gate right-hand pedestrian gate

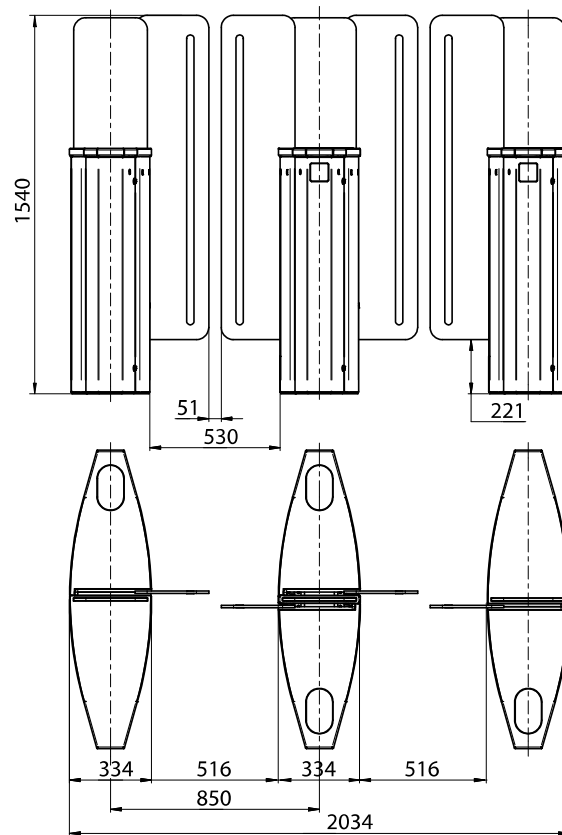

Figure 2 – Double «JETPAN» type turnstile (continued)

- four LED displays.
- There are installed inside extra pedestrian gate:

- terminal blocks;
- controllers;
- fourteen access sensors;
- two proximity card readers;
- power supply unit.

Optionally the turnstile can be completed with battery.

1.3.1.3 Design, overall and installation dimensions of pedestrian gates are specified in the Appendix A.

1.3.1.4 Manufacturing material of the turnstile is carbon steel subject to painting, brushed stainless steel or polished stainless steel.

1.3.2 Completeness of Delivery

The turnstile is delivered by one package.

Dimensions of package (WxLx H):

- for single turnstile 800x1380x1700mm;
- for double turnstile 1170x1380x1700mm.

Completeness of delivery is specified in the Table 5.

Table 5

Name of product	Product designation/parameters	Quantity, piece	Notes
Waist-high turnstile of «JETPAN» type	T3.KCD._____	1 kit	To be delivered by components
<u>Components</u>			
Left-hand pedestrian gate	–	<input type="text"/> pcs.	–
Right-hand pedestrian gate	–	<input type="text"/> pcs.	–
Extra pedestrian gate	–	<input type="text"/> pcs.	–
Mounting kit	Redibolt 92F112A2-0 (12×120 M10)	<input type="text"/> pcs.	–
Control panel	AUIA.114.02.00.00	<input type="text"/> pcs.	
Battery*	12V; 7A·h	<input type="text"/> pcs.	One backup power supply is installed on each pedestrian gate
Certificate	AUIA.165 PS	1	–
Packing		1	–
* Optional			

1.4 Design and operation

1.4.1 Turnstile design

1.4.1.1 Housing of pedestrian gate is a set of stainless steel side panels 3, 4, 5 (see the Appendix A), bottoms of which are rigidly fixed to the base 2 and on the top they are fixed to frames installed on casing 10. Two decorative covers 6 from artificial stone are mounted on the top of housing. An extra

vertical crossbar 7 with glass is mounted between covers to prevent unauthorized intrusion over upper horizontal surface of housing.

1.4.1.2 The turnstile’s status is displayed by LEDs 8, installed on frame of pedestrian gate. Constantly lit red LED means initial state of the turnstile. In case of attempt of unauthorized access red LED starts to blink and sound signal is generated. When opening command is received, signal is transformed to green arrow from the side of authorized access. If unauthorized access is attempted when leaves are open, the leaves will close if there is no any obstacle in the leaves moving area.

1.4.1.3 Seven infrared sensors 9, installed on side panels of the turnstile from access side, are designed for detection of turnstile access, preventing closing of leaves during pedestrian access in immediate proximity to them and minimizing potential for personal injury during turnstile access.

1.4.1.4 Leaf is made from 10mm tempered glass and is located in the middle of pedestrian gate housing on extension device 1. Each leaf is actuated by separate servomotor. Extra pedestrian gate is equipped with two servomotors (one per each passageway), while margin pedestrian gates (left-hand and right-hand) are equipped with one servomotor.

1.4.1.5 In case of 220V main power cut the turnstile’s blades will remain in the position in which they were, and operation of the turnstile will be maintained from battery (if it is installed).

1.4.1.6 Actuating mechanism of pedestrian gate, shown in the Figure 3, provides reliable mechanical locking of leaf in travel end points due to toothed-belt drive.

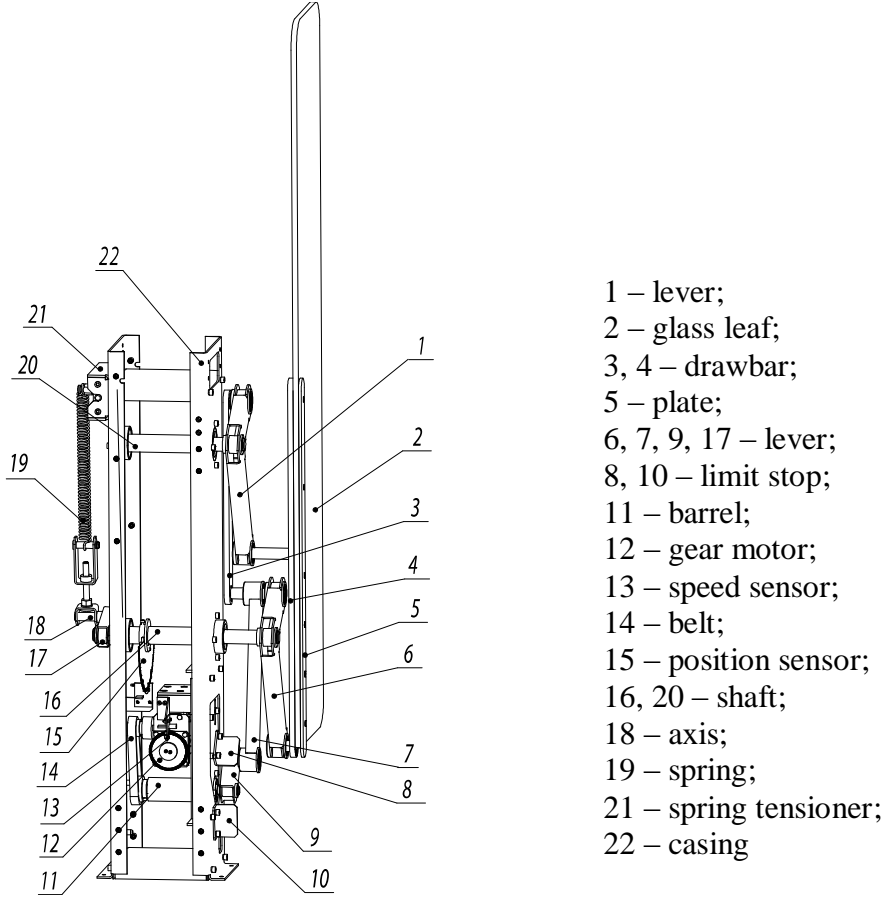

Figure 3 – Actuating mechanism of the «JETPAN» type turnstile

1.4.1.7 Inside the turnstile housing the panels are fixed on which controllers, power supply unit, battery and terminal blocks to be connected to 220V mains and control devices are installed.

Controllers PCB.201.01.00.00 control the turnstile’s motor analyzing signals from speed and position sensors, and provide overload protection. Controllers PCB.205.21.20.00 analyze infrared sensors,

receive control commands from peripherals (control panel, Access Control System (ACS) etc.), control LED displays and generate feedback signals for ACS.

1.4.1.8 External control panel has the following functions: single entry and exit, locking of entry and exit, free entry and exit.

1.4.2 Principle of operation

1.4.2.1 Cycle of access:

1. In the initial state the turnstile leaves are located transversely to housing barring the access.
2. The turnstile is open for access in the direction «A» or «B» after the appropriate command from ACS or control panel is received.
3. Green arrow is lit on LED display; leaves are pushed in the housing making reciprocal movement, i.e. they open. Pedestrian is able to access through the turnstile freely.
4. After pedestrian exit from control area, the «closed» mode is set until next access. Red LED is lit. Leaves are reliably closed preventing attempts of «access in echelon» or other unauthorized access.

More detailed description of the turnstile operating modes is given in the paragraph 1.8 «Description and operation of controller as the turnstile component».

1.4.2.2 12V DC power voltage is provided by power supply unit.

1.4.2.3 When mains power supply is cutoff, the turnstile is automatically switched to power supply from 12V, 7A·h battery (optional), which ensures the turnstile's operation within 2 hours.

1.4.2.4 The turnstile's wiring diagrams are shown in the Appendix C.



1.5 Instrumentation, tools and accessories

Dedicated tools are required for installation of the turnstile (multi-purpose measurement instrumentation and installation tools are enough).

1.6 Marking

1.6.1 Marking of turnstiles to be delivered within Ukraine is in Ukrainian language and for export delivery in English.

Each turnstile is marked as follows:

- name of manufacturer and trade mark;
- each turnstile is equipped with identification plate containing the following data;
- reference designation of turnstile modification;
- index of protection;
- serial number;
- value of voltage, type of current, frequency and current consumption;
- weight, kg;
- marks of conformity  .
- date of manufacture;
- inscription: «MADE IN UKRAINE».

Identification plate is located on the turnstile's post.

1.6.2 Marking of transportation packing contains as follows:

1) Information inscriptions:

- turnstile reference designation;
- dimensions of cargo package in centimeters;
- gross weight in kg;
- net weight in kg;
- volume of package in cubic meters;

2) Handling marks:

- «Fragile. Handle with Care»;
- «Keep dry»;
- «Centre of gravity»;

– «Top».

1.6.3 Shipping documentation is packed in a bag from polyethylene film. Marking is applied on insert from cardboard or paper.

1.7 Packing

1.7.1 The turnstile is delivered ready-to-install.

Types of packing:

- consumer packaging (corrugated cardboard case);
- transportation packaging (cases from wood-fiber board or crates).

The turnstile is fixed from displacement in the middle of transportation package with blocking lumbers. Cushion pads are placed between the turnstile and lumbers.

1.7.2 Shipping documentation sealed in a bag from polyethylene film is enclosed to the turnstile packing.

1.8 DESCRIPTION AND OPERATION OF CONTROLLER AS TURNSTILE COMPONENT

1.8.1 Controller PCB.205.21.20.00

1.8.1.1 Appearance of controller PCB.205.21.20.00 is shown in the Figure 4.

1.8.1.2 Description of operation

Controller provides algorithm of operation of the whole turnstile. It is assembled on the (120x110)mm card from foil-clad textile laminate, on which electronic components and terminals for connection to other turnstile units as well as for connection to control peripherals (ACS, control panel etc.) are installed.

Controller initiates signal for 7 infrared transmitters and receives signal from 7 infrared receivers that enables to determine human (or object) presence in the turnstile access area with high probability. Furthermore, controller manages light and sound indication, receives commands from control panel using interface RS-485, receives commands and initiates report signals for ACS via signal inputs and outputs as well as manages operation of motor controllers (PCB.201.01.00.00).

Controller and therefore turnstile can be in the following modes:

- «INITIAL STATE».
- «SINGLE ACCESS IN THE DIRECTION A».
- «SINGLE ACCESS IN THE DIRECTION B».
- «SINGLE ACCESS IN BOTH DIRECTIONS».
- «FREE ACCESS IN THE DIRECTION A».
- «FREE ACCESS IN THE DIRECTION B».
- «FREE ACCESS IN BOTH DIRECTIONS».
- «LOCKING OF ACCESS IN THE DIRECTION A».
- «LOCKING OF ACCESS IN THE DIRECTION B».
- «LOCKING OF ACCESS IN BOTH DIRECTIONS».
- «ALARM».

«INITIAL STATE»

Turnstile is in this mode during energizing and after completion of turnstile access, if during access the mode is not changed to «LOCKING», «FREE» or «ALARM». In this mode red LED is constantly lit on both cards, sound indication is off, access is barred by leaves.

«SINGLE ACCESS»

Turnstile goes to this mode when command «SINGLE ACCESS A/B» arrives from control panel via interface RS-485 or when signal inputs «INP4» («PERMISSION OF ACCESS A») or/and «INP5» («PERMISSION OF ACCESS B») are closed on common wire (terminal «GND»).

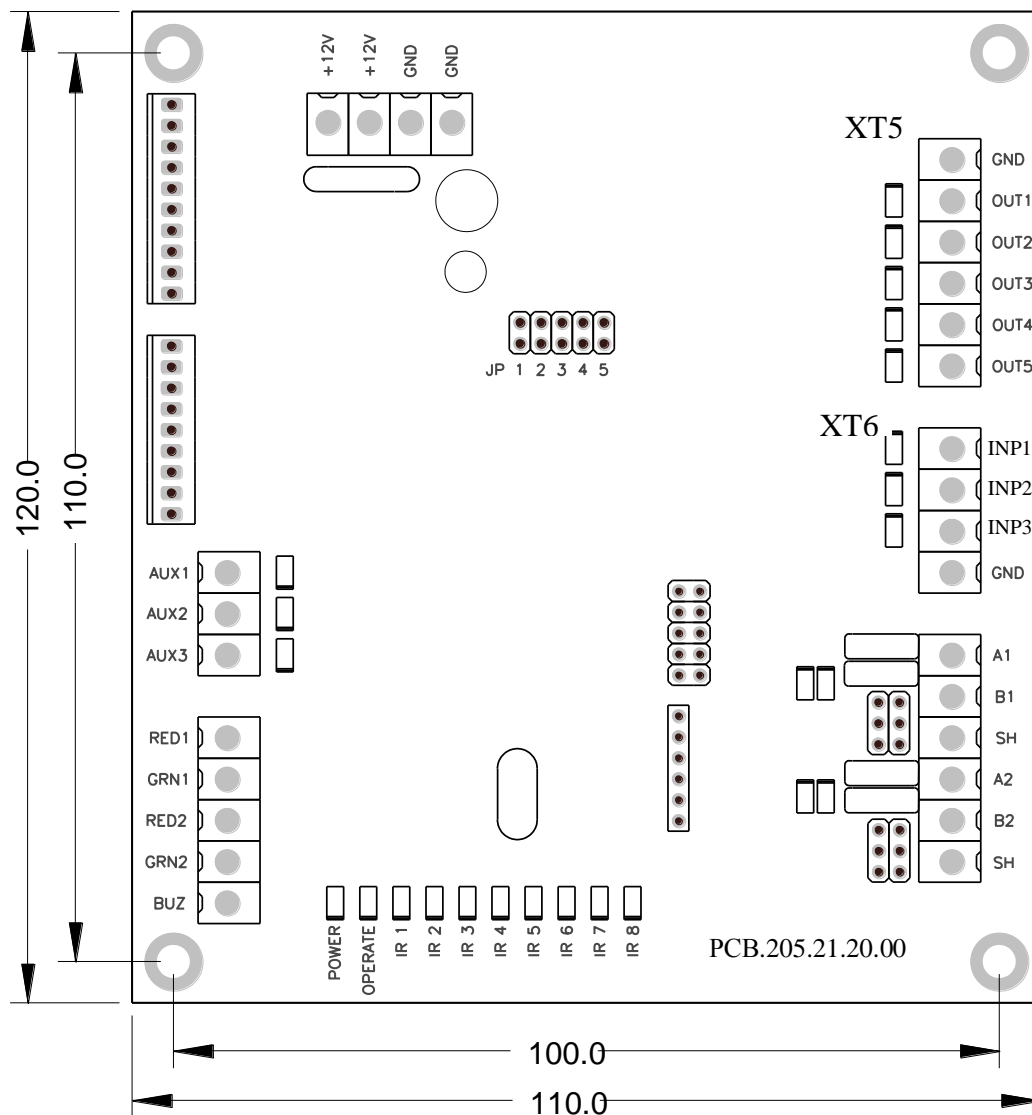

Figure 4 – Appearance of controller PCB.205.21.20.00

In this case if command comes via interface RS-485, the access start waiting time is 5 sec. and when signal inputs are short circuited the turnstile will be waiting for access start while input is closed.

Green arrow is lit on LED display from the side of permitted access and red cross is lit from the side of denied access. Leaves turn to 90° in the direction of permitted access. Pedestrian is able to access through the turnstile. If access start time is up and access is not started (the first IR barrier in the direction of movement was not barred), the turnstile returns to «INITIAL STATE». If within the above time period access is started, controller generates the signal «ACCESS IS OCCUPIED» (outputs «OUT1» or/and «OUT2») and starts tracing position and direction of pedestrian movement in turnstile passage, analyzing 7 IR barriers. As soon as pedestrian is behind swing panels they are closed, controller generates the signal «DETECTION OF ACCESS» (outputs «OUT3» or «OUT4») and LED display is switched from green to red. After pedestrian turnstile access controller deenergizes the signal «ACCESS IS OCCUPIED» and returns to «INITIAL STATE».

«FREE ACCESS»

Turnstile goes to this mode either upon command «FREE ACCESS A/B» arrived via interface RS-485 from control panel or if during «SINGLE ACCESS» initiated by signal on input «INP4» («PERMISSION OF ACCESS A») or/and «INP5» («PERMISSION OF ACCESS B») at the end of 0,3

sec. after the signal «DETECTION OF ACCESS A» or «DETECTION OF ACCESS B» deenergized by controller, the signal on the relevant input «INP1» or «INP2» is not deenergized.

In this mode swing panels are constantly turned in the direction of free access, green arrow is blinking on LED display from the side of permitted access. Thus every turnstile access is traced and the signal «DETECTION OF ACCESS» is generated to the relevant output («OUT3» or «OUT4»).

In this state turnstile will be until arrival of command «CANCELLATION OF FREE ACCESS» via interface RS-485 or until deenergization of the signals from «INP1» or/and «INP2» depending on the cause of going to the free access mode.

«LOCKING OF ACCESS»

Turnstile goes to this mode only upon command «LOCKING OF ACCESS A/B» arrived via interface RS-485 from control panel.

Thus red LED is blinking from the side of locked access, swing panels are in closed state (if turnstile is not open for free or single access from opposite side), controller does not respond to the signals of inputs «INP1» (PERMISSION OF ACCESS A) or/and «INP2» (PERMISSION OF ACCESS B) respectively.

Lock mode prevails over single and free access mode. It means that access can be locked at any time, thus, if within swing panels closing area there is no any obstacle they will be closed.

In this mode controller will be until arrival of command «CANCELLATION OF ACCESS LOCKING» via interface RS-485 from the control panel of the command «CANCELLATION OF A/B ACCESS LOCKING».

«ALARM»

Turnstile goes to this mode from any above mentioned mode in case of unauthorized access. Meanwhile red LED is frequently blinking (4 times per second), siren alarm is on the turnstile and control panel and output «OUT5» is activated on controller card. If turnstile was open, then swing panels would be closed if no obstacles were present in the closing area. Turnstile will return to the mode preceding the «ALARM» mode as soon as causes of this mode disappear. In this case the output «OUT5» will go to passive state, siren alarms on the turnstile on control panel are off and swing panels and light indication will be set according to the current mode.

Purpose of controller's contacts intended for connection to peripherals is specified in Table 6.

Table 6

Connector/ contact No.	Description	Direction	Designation	Signal description and parameters
XT6/1	INP1 («TO BE OPENED A»)	ENTRY	Command «TO BE OPENED FOR SINGLE/FREE ACCESS»	1) logical «0» (0÷2,2)V; 2) logical «1» (3÷5)V; 3) active level of signal (factory setting) logical «0»; 4) voltage on open input < 5 V;
XT6/2	INP2 («TO BE OPENED B»)	ENTRY		
XT6/4	GND		COMMON WIRE	
XT5/1	GND		COMMON WIRE	
XT5/2	OUT1 («ACCESS A IS OCCUPIED»)	EXIT	Signal is generated from the moment of barring of the first IR barrier in the direction of movement and is deenergized after cancellation of the latter	1) type of output – open collector; 2) peak voltage on privacy key 55V; 3) peak current of public key 100mA; 4) resistance of public
XT5/3	OUT2 («ACCESS B IS OCCUPIED»)	EXIT		
XT5/4	OUT3			

	(«DETECTION OF ACCESS A»)	EXIT	barring of the second last IR barrier and takes 0,2 sec.	key (5÷7)Ohm; 5) active level of signal (factory setting) – logical «0» (connection on GND)
XT5/5	OUT4 («DETECTION OF ACCESS B»)	EXIT		
XT5/6	OUT5 («ALARM»)	EXIT	Output is active in case of attempt of unauthorized access	

1.8.2 Controller PCB.201.01.00.00

1.8.2.1 Appearance of controller PCB.201.01.00.00 is shown in the Figure 5.

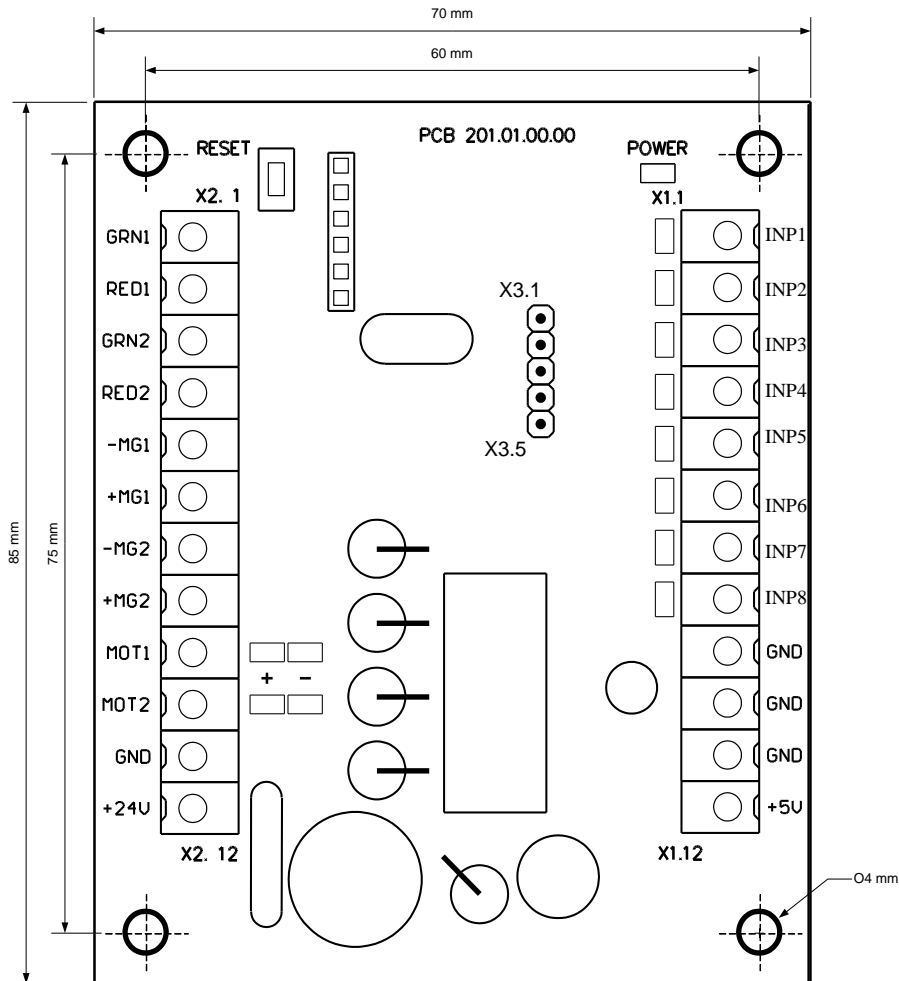

Figure 5 – Appearance of controller PCB.201.01.00.00

1.8.2.2 Description of operation

Controller is designed for management of DC motor, intended for movement of turnstile leaves, and electromagnetic brake installed on the motor shaft. Control is performed based on the signals arrived from optical motor speed and leaf position sensors as well as from the motor current sensor. Control commands come to the inputs «IN1» and «IN2» from controller PCB.205.21.20.00.

2 INTENDED USE

2.1 Operation limitations

2.1.1 The turnstile must be used in the environment specified in the p. 1.1.4 of this document subject to the specifications listed in the section 1.2.

2.1.2 IT IS PROHIBITED:

- 1) **UNINTENDED USE OF THE TURNSTILE** (see the section 1 «DESCRIPTION AND OPERATION»);
- 2) **TO USE THE TURNSTILE UNEARTHED;**
- 3) **TO USE HEATING PIPES AND RADIATIONS AS WELL AS PIPES OF CENTRAL WATER SUPPLY FOR EARTHING;**
- 4) **TO REPAIR AND ADJUST WITHOUT DEENERGIZING.**

2.1.3 It is not allowed to use the turnstile:

- at the presence of mechanical rattle in movable parts of the turnstile;
- when metalwork of the turnstile and its components and accessories are mechanically damaged.

2.1.4 List of special conditions of operation

- Mean time of the turnstile access (in single access mode) equals to 2 sec.
- For increasing of the turnstile's traffic flow capacity in case of emergency escape door or gate can be installed near the turnstile.

ATTENTION: MANUFACTURER WARNS OF NECESSITY TO KEEP SEALS OF THE MANUFACTURER ON THE TURNSTILE'S COMPONENT PARTS!

2.2 Layout and installation

2.2.1 The turnstile and components of delivery kit are delivered to installation site in the factory packing. The turnstile should be unpacked only on installation site.

2.2.2 Preparation of the turnstile for installation (dismounting) and commissioning should be performed according to this OM with mandatory observation of the safety measures specified in p. 2.1 and general electrical safety code.

2.2.3 The turnstile should be installed in the following order:

- inspect the turnstile for integrity, absence of visual damages and defects;
- verify the turnstile's completeness;
- prepare installation site for mounting of the turnstile: surface should be plain, hard and without defects (corrugations, overlaps etc.);
- mark the hole drilling places according to the Appendix A. Installation and fixation of the turnstile should be performed only after all the turnstile electrical connection cables are pulled.

ATTENTION! Pedestrian gates are linked by control line of optical sensor system demanding accurate positioning of pedestrian gates. Relative position of pedestrian gates and vertical position of the turnstile should be followed.

Side plates 3 should be opened to provide access to fixation holes. Side plates are made in the form of hinged door and are closed by locks. Unlock and open side plates, then remove covers 6 and side plates 4, 5 (see the Appendix A). Fix the turnstile on installation site by means of Redibolt (anchor with jacket and screw). Make sure of stability of the installed turnstile;

- earth the turnstile, connect power cable to the turnstile according to the wiring diagram (see the Appendix C).

After the required installation is completed, appropriate parts of the turnstile should be put back to their fixation places and locked.

2.3 Preparation for use

2.3.1 Commissioning instructions

Prior to energizing of the turnstile:

- 1) make sure of proper connection and good condition of all connecting cables;
- 2) clear the area of the turnstile's leaves turning from foreign particles.

When mains cable of power supply unit is connected to the network, the turnstile's actuating mechanism is energized. Access is barred by leaves.

The turnstile is set in initial state: entry and exit LED displays are red (« >< » is lit).

2.3.2 Required inspections

2.3.2.1 When the turnstile is commissioned it is necessary to perform inspections specified in the Table 7. During inspections the wiring diagram according to the Appendix C and the control panel according to the Appendix B should be used.

Table 7

Operation Mode	Mode Setting	LED Display
1 Turnstile is closed in both directions (initial state)	–	Red LED is lit
2 Single access in one direction	Push the «SINGLE» access button to access in selected direction («A» or «B»)	Green arrows of single access is lit in the authorized direction and red arrow is lit in opposite direction
3 Single access in both directions	Push both «SINGLE» access buttons to access in two directions («A» or «B»)	Green arrows of single access are lit in both directions
4 Free access in one direction	Push the «FREE» access button to access in the selected direction («A» or «B»)	Green arrow of free access in the selected direction is blinking and red arrow is lit in opposite direction
5 Free access in both directions	Push both «FREE» access buttons to access in two directions («A» or «B»)	Green arrows of authorized free access are blinking in both directions
6 Single access in one direction and free access in opposite direction	Push the «SINGLE» access button to access in the selected direction and «FREE» access button to pass in opposite direction	Green arrow is lit in the single access direction and green arrow is blinking in free access direction
7 Single access in one direction and locked access in opposite direction	Push the «SINGLE» access button to access in the selected direction («A» or «B») and the «LOCK» button to lock access in opposite direction	Green arrow is lit in the single access direction and red arrow is blinking in the locked access direction
8 Free access in one direction and locked access in opposite direction	Push the «FREE» access button to access in selected direction («A» or «B») and the «LOCKING» button to lock access in opposite direction	Green arrow is blinking in the free access direction and red arrow is blinking in the locked access direction
9 Locked access in one direction	Push the «LOCKING» button to lock access in selected direction («A» or «B»)*	Red arrow of locked access in one selected direction is blinking
10 Locked access in both directions	Push both «LOCKING» buttons to lock access in two directions («A» or «B»)**	Red arrows of locked access in both directions are blinking
* In this case other control panel buttons of single and free access in selected direction are locked		
** In this case all control panel buttons of single and free access in both directions are locked		

2.3.2.2 When the turnstile is inspected it is ready for long-term operation.

2.4 Contingency actions

For emergency evacuation (in case of fire, acts of God etc.) and providing free access the turnstile must be unlocked from control panel by sending the relevant command.

3 MAINTENANCE

3.1 General instructions

3.1.1 Commissioning and subsequent maintenance of the turnstile should be performed only by the staff to be in charge of the turnstile.

3.1.2 The turnstile can be serviced only by the staff having the relevant electrical safety qualification level according to the national requirements.

3.1.3 The turnstile can be installed and operated only by the qualified safety instructed staff having the relevant class of permit to work with electrical facilities with voltage up to 1000V, aware of this OM, design and the turnstile's principle of operation.

3.2 Safety Measures

3.2.1 During maintenance of the turnstile the relevant safety measures, specified in p. 2.1, must be observed.

IT IS FORBIDDEN TO USE DEFECTIVE APPLIANCES, TOOLS, FUSES, INSTRUMENTATION SERVICE LIFE OF WHICH EXPIRED. MEASURING DEVICES, WHICH TERM OF CHECKING HAS ENDED.

3.2.2 When instrumentations are prepared for operation it is necessary to comply with the safety requirements specified in instrumentation instruction manuals.

3.3 Maintenance procedure

3.3.1 Maintenance of the turnstile includes preventive measures which are taken according to established frequency to maintain the turnstile in operational condition, decreasing of component wearing and prevention of faults and malfunctions.

3.3.2 Daily and periodic maintenance of the turnstile are recommended.

Normally the daily maintenance is carried out before the beginning of work or during operational timeout and includes visual inspection of the turnstile's housing, and, if required, mechanical troubleshooting, elimination of corrosion and pollution from the surface.

IT IS FORBIDDEN TO USE ABRASIVE AND CHEMICALLY ACTIVE SUBSTANCES DURING CLEANING OF CONTAMINATED EXTERNAL SURFACES OF THE PRODUCT.

3.3.3 Periodic maintenance is performed at least twice a year and includes as follows:

- visual inspection of the turnstile's housing, control mechanism and other components for absence of corrosion, warps and other mechanical defects and pollutions;
- visual inspection of connecting, network and grounding cables condition;
- during manual control in the modes specified in the Table 7 or when identification cards are used;
- checking of reliability of the turnstile's screw joints.

4 ROUTINE MAINTENANCE

4.1 General instructions

Possible malfunctions of the turnstile are listed in the Table 8 and are remedied by customer. More complicated malfunctions are remedied by manufacturer's representative.

ATTENTION: INSPECTION, CLEANING, REPAIR OF THE TURNSTILE'S COMPONENTS MUST BE PERFORMED ONLY AFTER DEENERGIZING OF THE TURNSTILE!

4.2 List of possible malfunctions

List of possible malfunctions of the turnstile and their remedies are specified in the Table 8.

Table 8

Symptom	Possible cause	Remedy
1 Turnstile locking is not provided	Electric circuit is broken	Malfunction to be discovered and remedied
2 Lack of 12V voltage	Power supply unit is out of order	Power supply unit to be replaced
3 When the mains power supply is off the turnstile does not operate from battery	Battery is discharged	Battery servicing according to its instruction manuals to be performed
	Battery service life expired	Battery to be replaced

4.3 Postrepair checkout

After repair the turnstile's operating capacity is checked according to p. 2.3.2.

5 TRANSPORTATION AND STORAGE

5.1 It is forbidden to subject the turnstile to jerks and impacts during storage. For lifting and handling of the turnstile it is necessary to use transportation trolleys. In storage facility there should not be aggressive gases and vapours causing corrosion. Storage ambient temperature should not be below +5°C and above +40°C and relative humidity should not be more than 80% at the temperature 20°C.

5.2 The ready-to-install turnstile is transported in railway or special containers, closed vehicle, waterborne (in ship's hold) according to the transportation regulations related to the relevant mode of transport.

Transportation on open platforms is allowed. In this case the packed turnstile should be covered with canvas. Ambient temperature during transportation should not be below -40°C and above +50°C.

After transportation or storage of the turnstile at negative temperatures or increased humidity the turnstile should be kept indoor with normal climatic conditions without original packing within 12 hours before commissioning:

- 1) ambient temperature: + 15°C to +35°C;
- 2) relative humidity: 45% to 80 %;
- 3) atmospheric pressure: 84,0 to 106,7kPa (630-800 mm Hg).

6 UTILIZATION

The turnstile does not contain hazardous materials and special measures are not required for utilization.

7 MANUFACTURER'S WARRANTY AND CONDITIONS OF WARRANTY MEAINTEANCE

7.1 The manufacturer guarantees good state and declared quality of the turnstile if conditions of transportation, storage, installation and operation are observed by the client.

7.2 The warranty period of the turnstile from the date of sale is 12 months, unless otherwise specified by mutual agreement.

Manufacturer:
«TiSO-PRODUCTION» Company
72 Yamskaya str., 03680, Kiev, Ukraine
Tel.: +38 (044) 461-79-69
Tel./Fax: +38 (044) 586-46-47
E-mail: export@tiso.ua, log1@tiso.ua
www.tiso-turnstiles.com

Our equipment complies with requirements of the European Standards:

EN ISO 12100:2010; EN 614-1:2006+A1:2009; EN 1037:1995+A1:2008; EN 60204-1:2006; EN 953:1997+A1:2009; ISO 3864:1995; EN ISO 13857:2008; EN ISO 13849-1:2006; EN 1088:1995; EN ISO 13732-1:2008

and is in conformity with requirements of the following EC Directives:
2004/108/EC; 2006/95/ EC; 2006/42/ EC



Appendix A
 Design, overall and installation dimensions of the turnstile

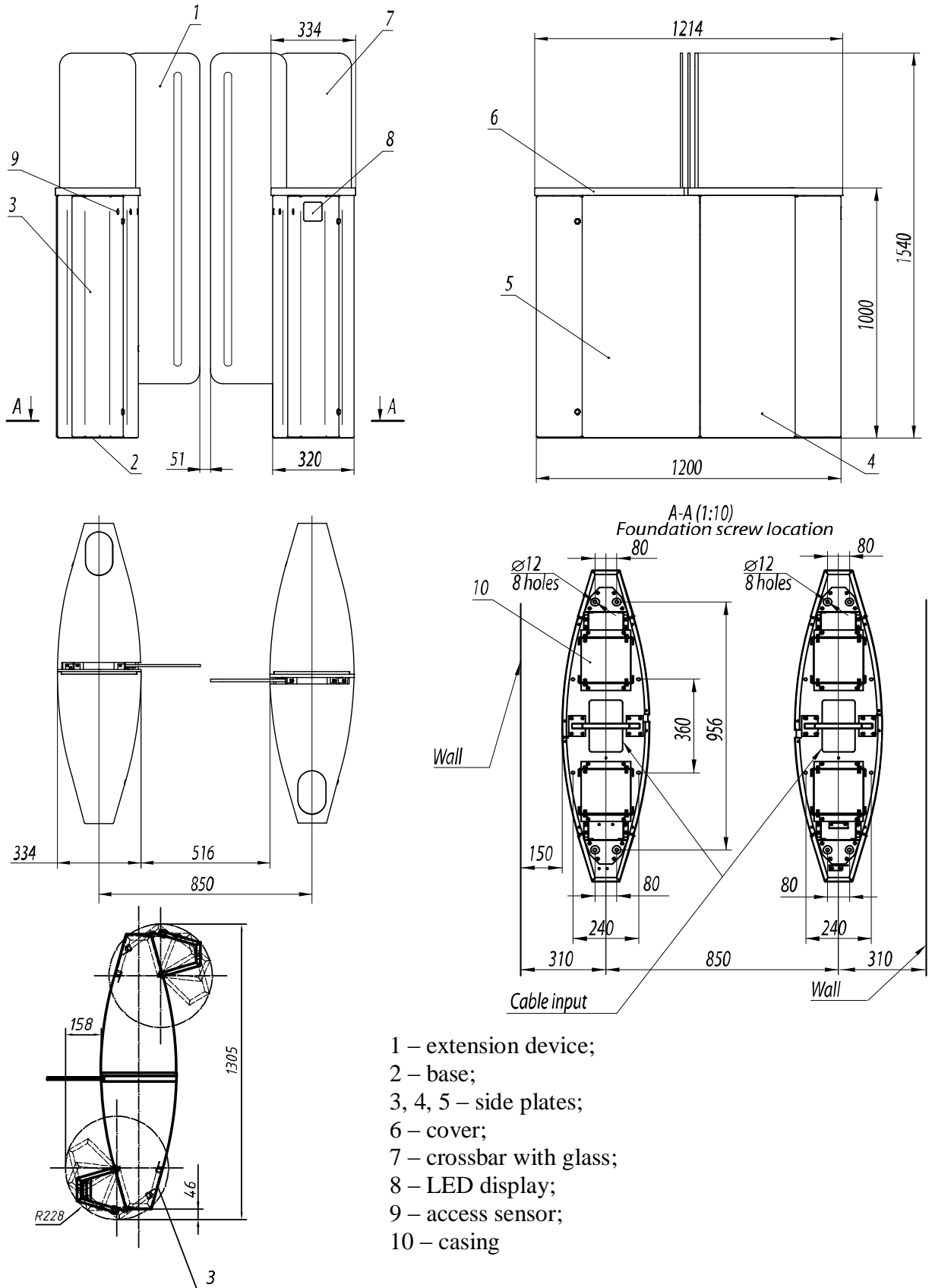
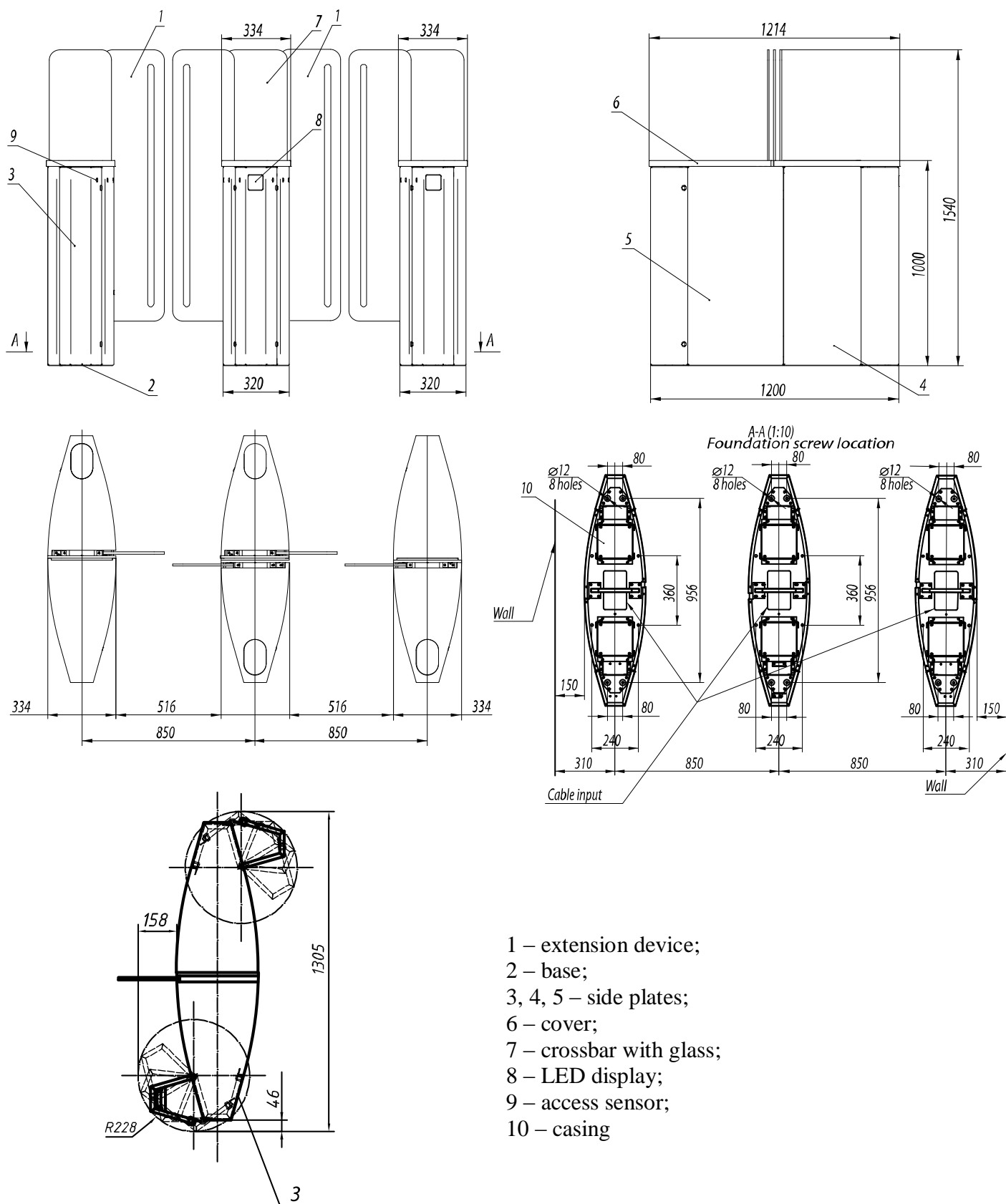

Figure A.1 – Single «JETPAN» type turnstile

Appendix A (continued)
 Design, overall and installation dimensions of the turnstile



- 1 – extension device;
- 2 – base;
- 3, 4, 5 – side plates;
- 6 – cover;
- 7 – crossbar with glass;
- 8 – LED display;
- 9 – access sensor;
- 10 – casing

Figure A.2 – Double «JETPAN» type turnstile

Appendix B
Control panel and connection diagram

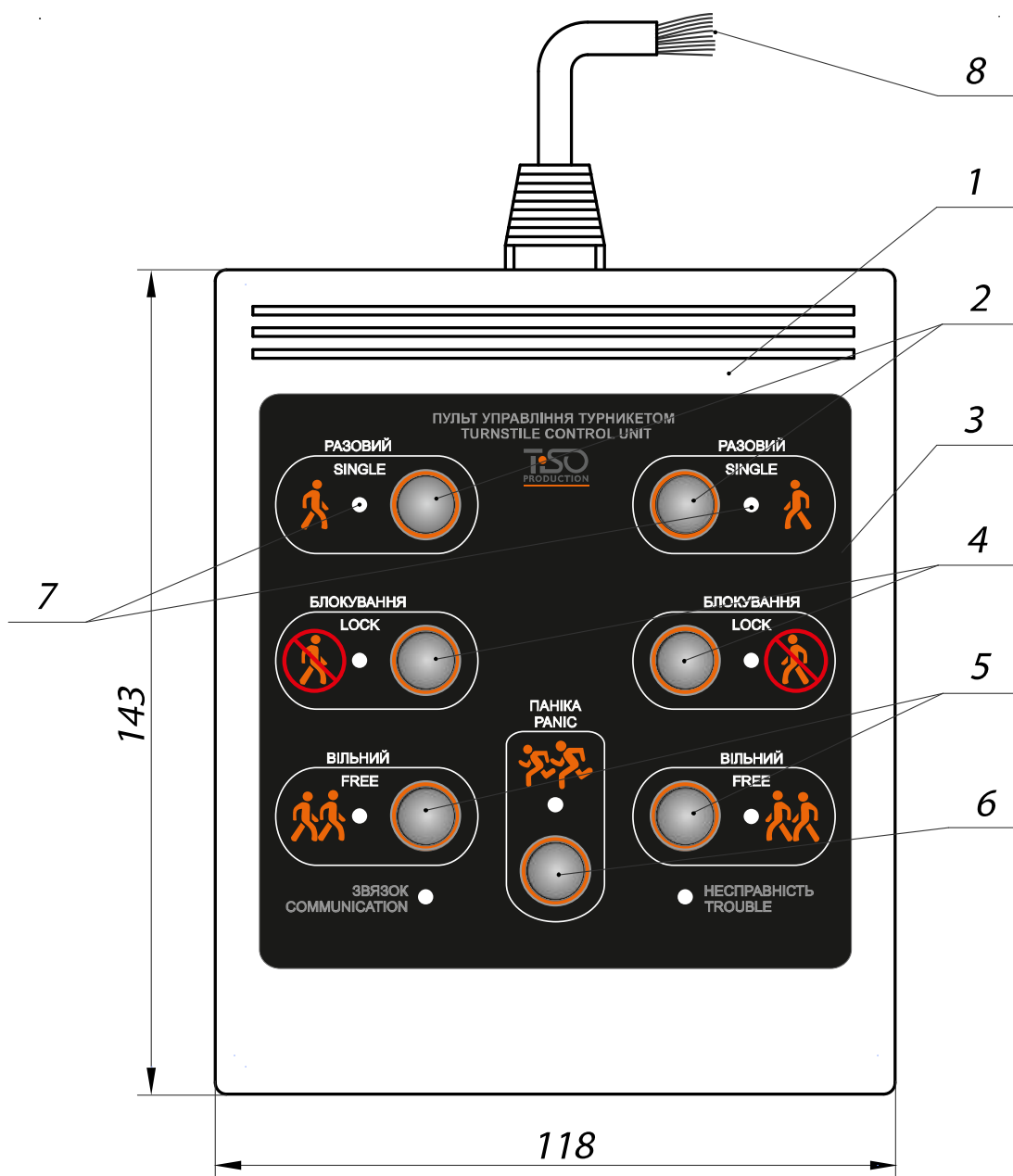

- | | |
|---|---------------------------------------|
| 1 – housing of control panel; | 5 – «FREE ACCESS» mode control button |
| 2 – «SINGLE ACCESS» mode control button | 6 – «PANIC» mode control button; |
| 3 – front plate; | 7 – access direction LED display; |
| 4 – «LOCKING» mode control button; | 8 – controller connection terminals |

Figure B.1 – Control panel AUIA.114.02.00.00

Appendix B (continued)
Control panel and connection diagram

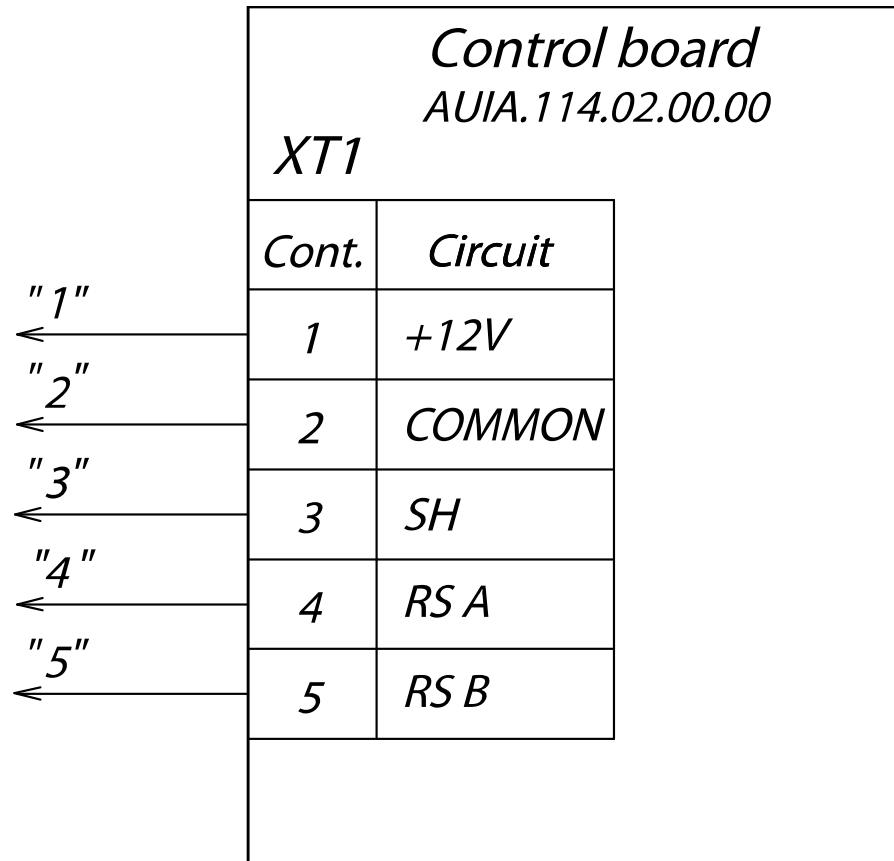

Figure B.2 – Connection diagram of control panel AUIA.114.02.00.00

Appendix C
Wiring Diagram of the turnstile of «JETPAN» type

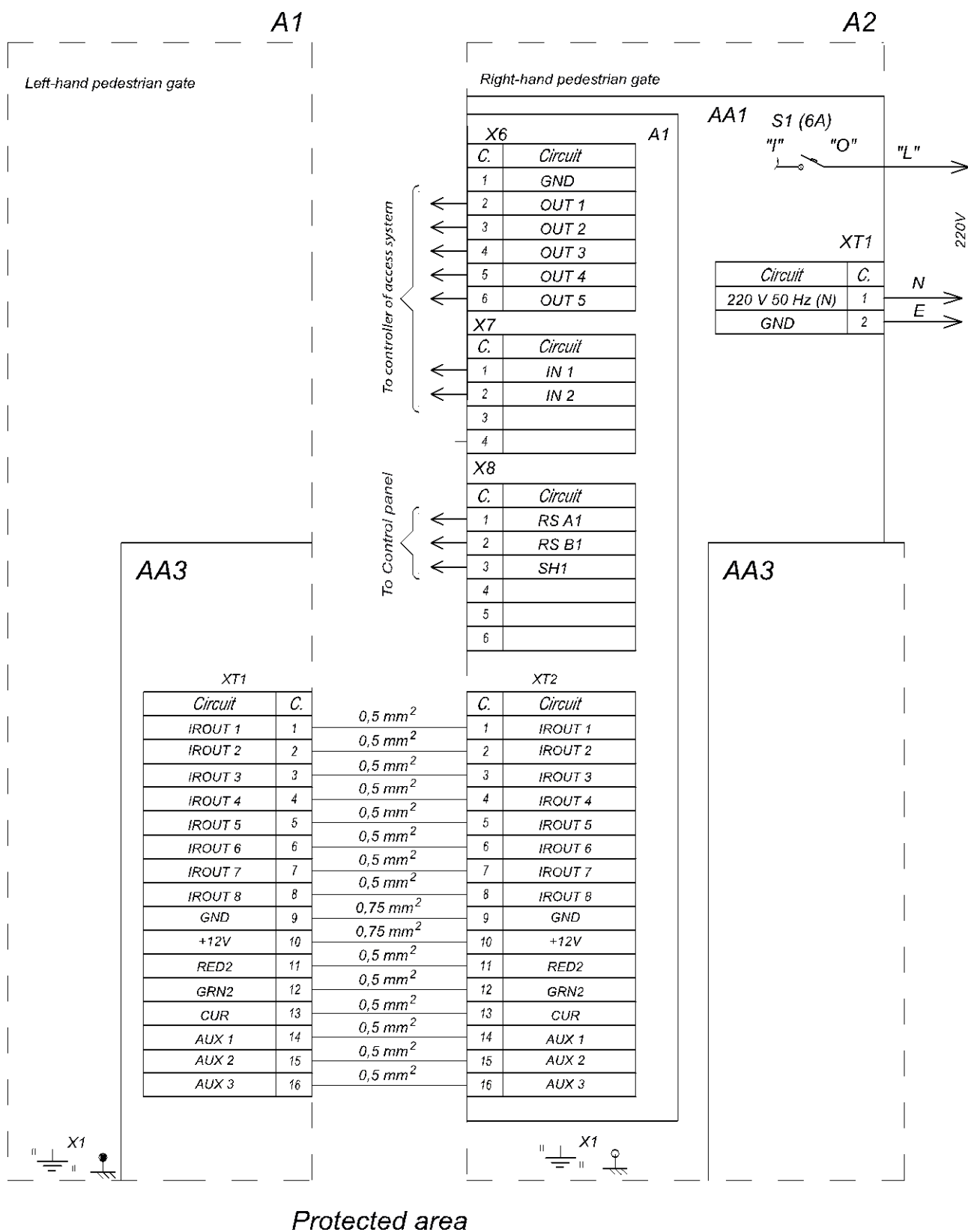

Figure C.1 – Wiring Diagram of Single Access Turnstile

Appendix C (continued)
Wiring Diagram of the «JETPAN» type Turnstile

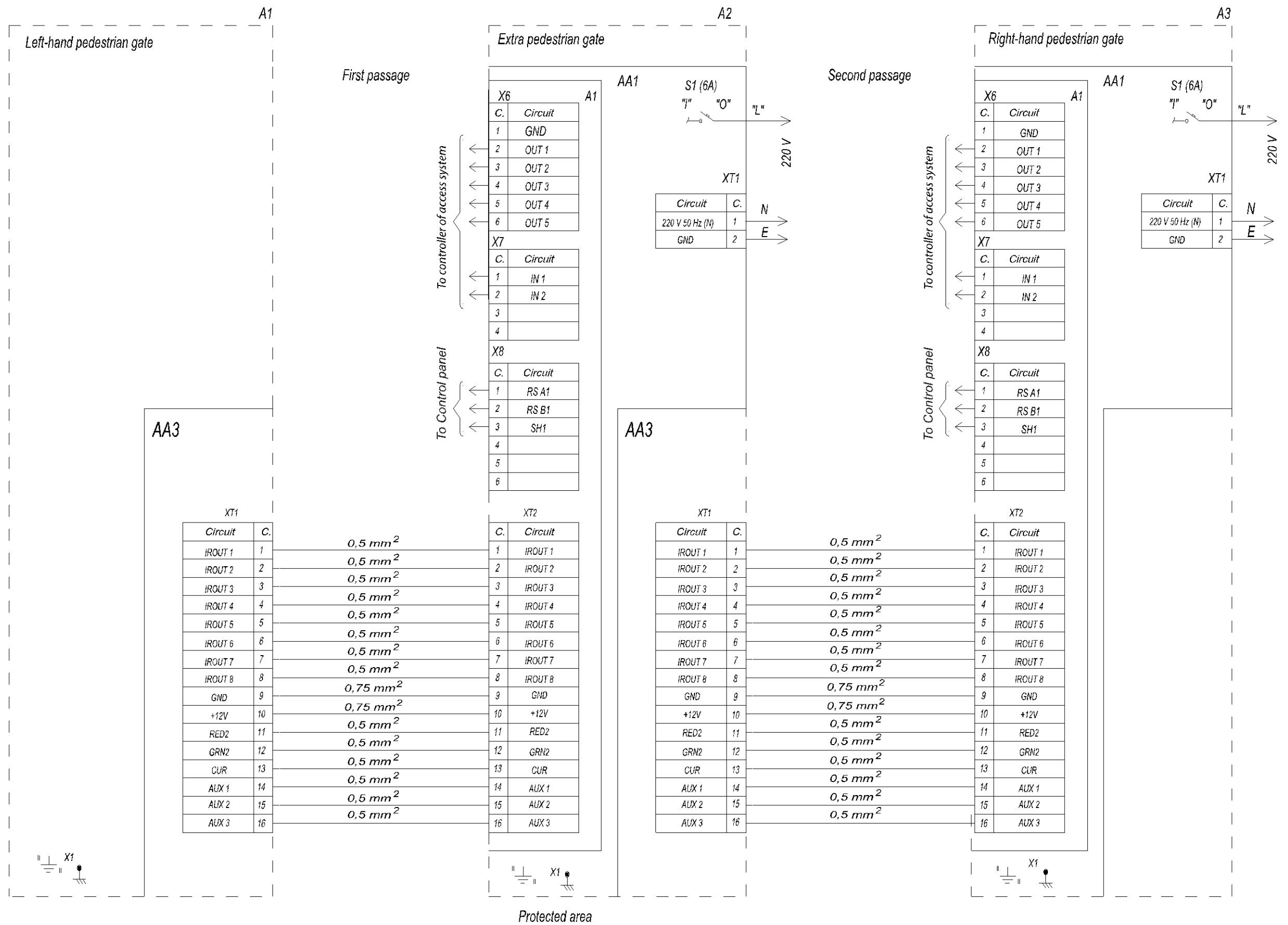
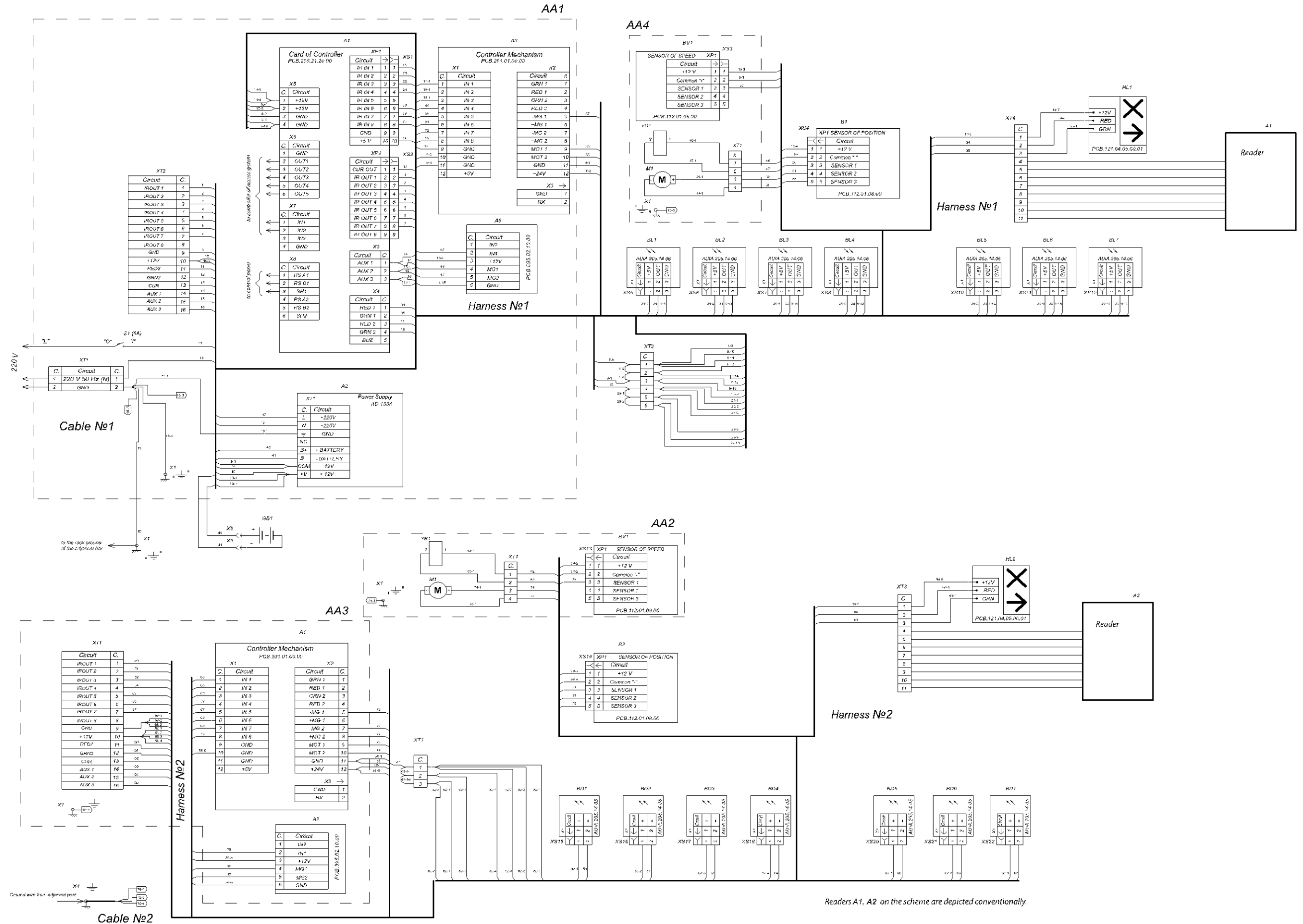

Figure C.2 – Wiring Diagram of Double Access Turnstile

Appendix C (continued)
Wiring Diagram of the «JETPAN» type Turnstile



Readers A1, A2 on the scheme are depicted conventionally.

Figure C.3 – Wiring Diagram of Extra Pedestrian Gate

Appendix C (continued)
 Wiring Diagram of the «JETPAN» type turnstile

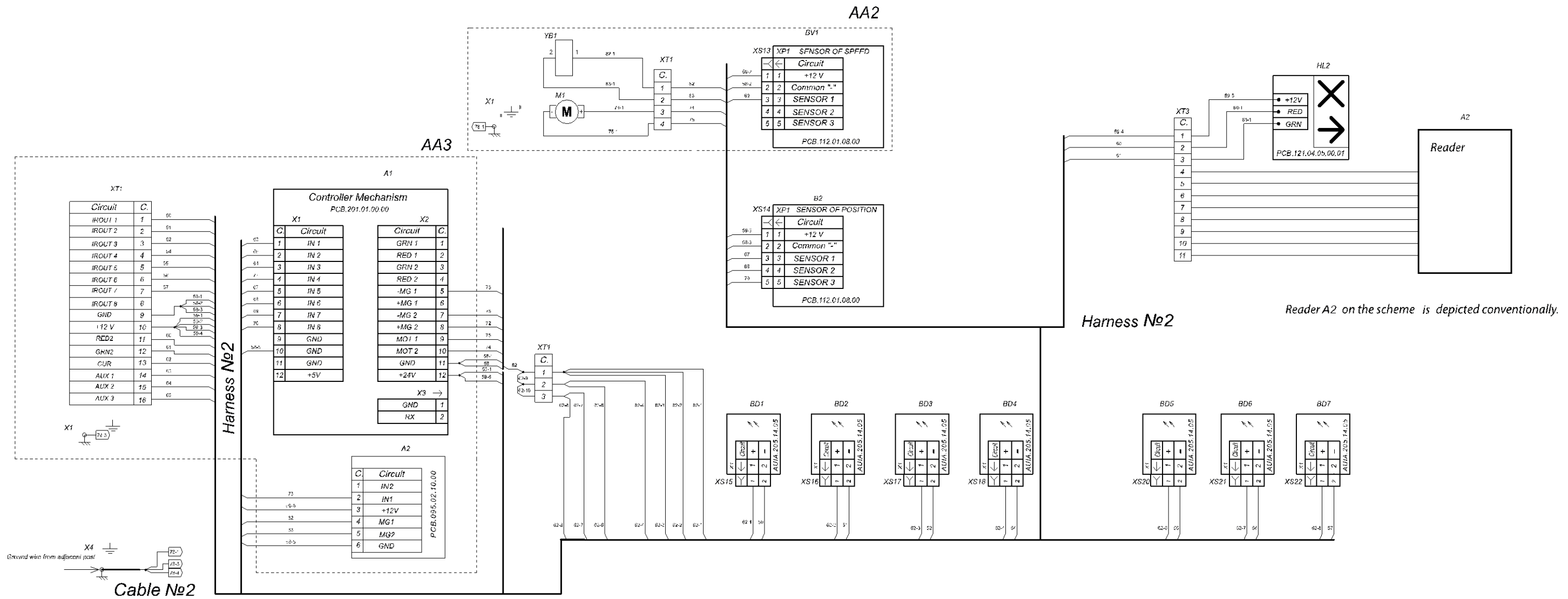

Figure C.4 – Wiring Diagram of Left-Hand Pedestrian Gate

Appendix C (continued)
Wiring Diagram of the «JETPAN» type turnstile

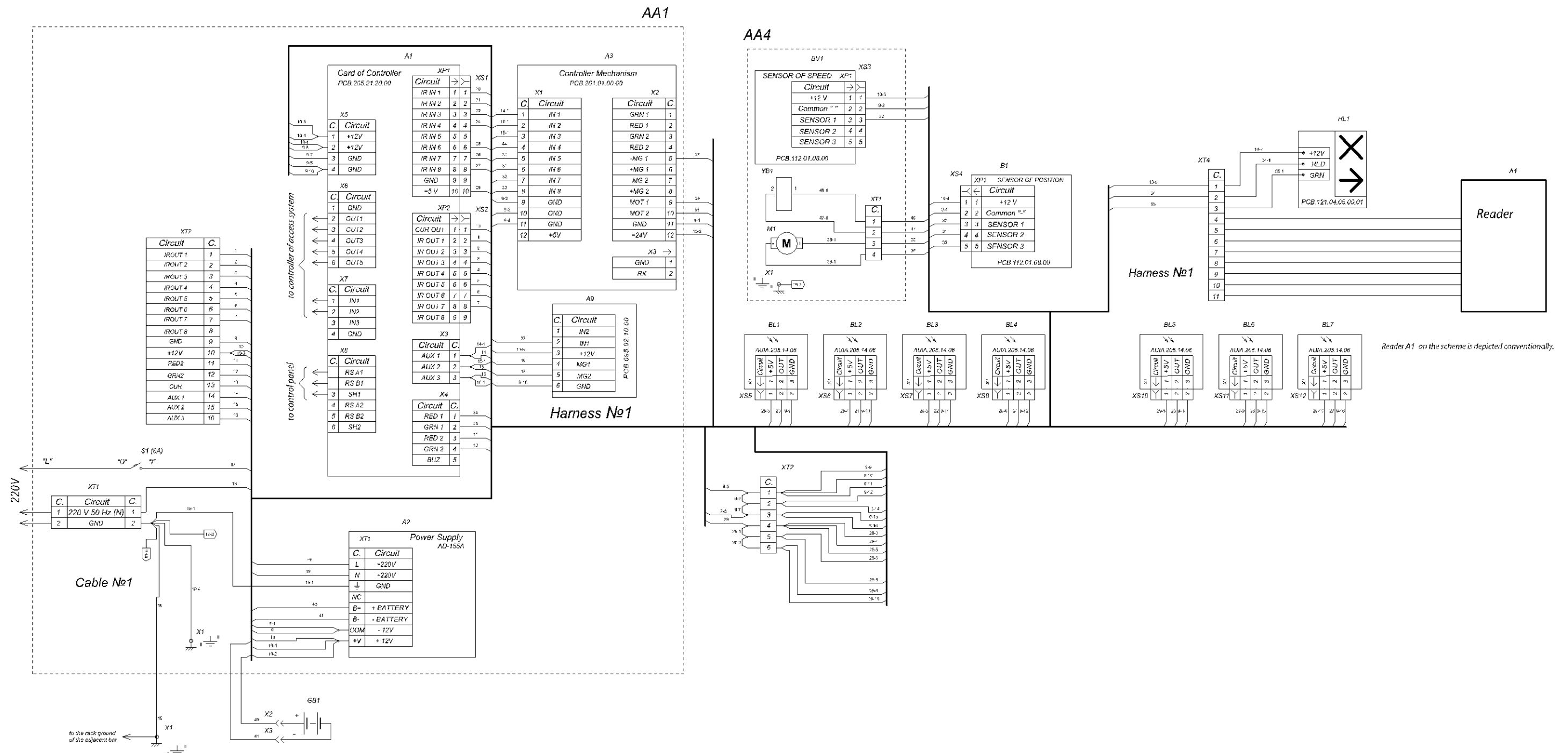

Figure C.5 – Wiring Diagram of Right-Hand Pedestrian Gate